



GLASS DOOR REFRIGERATOR

User manual



NA-24R

Read this manual carefully before you operate the machine.
Properly keep this manual for any future reference.



Prepared by Distex M&M Inc.

Dear customer:

Please follow the manual to achieve the best service performance and the longest service life for machines.

CONTENT

1. Exterior Appearance	2
2. Transport and Storage	3
3. Safety Precautions	3
4. Startup and Temperature Regulation.	4
5. Usage precautions.	4
6. General faults and Trouble-Shooting	5
7. Major Technical Parameters	6
8. Replacement of Lamp	6
9. Disposal of Old Appliances	7
10.Circuit Diagram	9
11.Packing List	9

1. EXTERIOR APPEARANCE

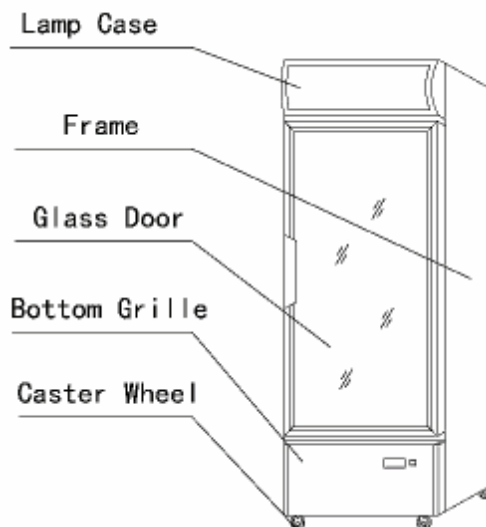
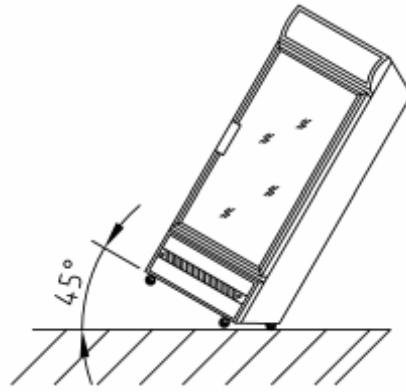

Figure 1

2. TRANSPORT AND STORAGE

- 1) Keep steady when loading and unloading, especially those with glass doors; the angle of inclination in the transit of the refrigerator should not be more than 45 degrees. (Figure 2)
- 2) The refrigerator should be placed in a well-ventilated, dry and cool place, avoiding direct exposure to sunlight. (Figure 3)
- 3) Remove the packing material before use; and arrange for the refrigerator less than 150mm away from the wall at the back and side. (Figure 4)
- 4) Place the refrigerator on a sturdy and leveled floor.



The angle of inclination in the transit of the refrigerator should not be more than 45 degrees

Figure 2

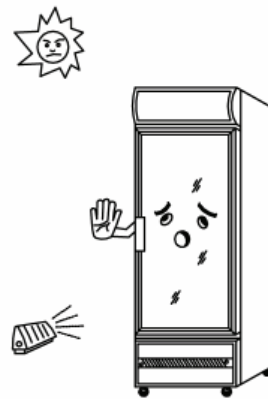

Avoid direct exposure to sunlight and extreme temperature

Figure 3

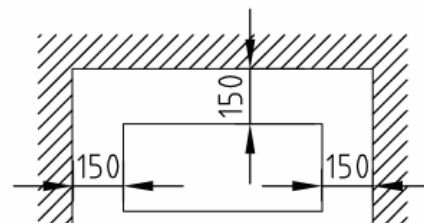

Arrange for the refrigerator less than 150 mm away from the wall at the back and side

Figure 4

3. SAFETY REGULATIONS

- 1) Use an independent 3-pole electrical outlet and cable with a capacity of no less than 10A; the outlet should be properly grounded, and the direct connection of the earth to the tapping pipes and the gas pipes are prohibited.
- 2) Single phase and alternating current with voltage and frequency to the relevant specification are required for the refrigerator; should the voltage either be lower than 85% or higher than 110% of the rated value. A voltage regulator with an input power 5 times as large is installed.
- 3) Unplug the refrigerator if it is going to be left unused for quite

a long period of time; check if the connection is ok before it is put into use again.

4. STARTUP AND TEMPERATURE REGULATIONS

1) Turn on the power of the refrigerator, the fan starts running, and the compressor starts up. The machine begins to refrigerate. The thermostat and lamp switch position on left hand side internally. After opening the glass door, switching it, the external and internal light will be on. If it is not necessary you can switch the light off.

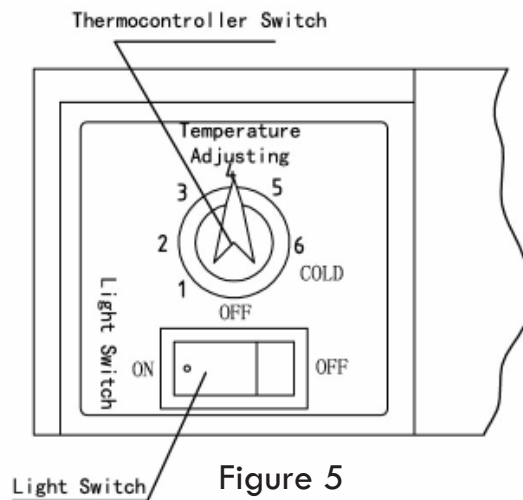

Figure 5

2) Temperature Regulations:

The temperature gradually drops when you switch the knob of the thermostat clockwise, and gains when anticlockwise. When the arrow in the knob is pointed to extreme cold, the air compressor will keep working; but it is not recommended to use the refrigerator for too long in such extreme temperature conditions for possible faults of the compressor.

5. USAGE PRECAUTIONS

1) The refrigerator cannot be re-started until after half an hour on the leveled floor it is moved to. Before the first use, it should be running for about 2 hours before food is put into the cabinet for storage.

2) It is not allowed to switch on the refrigerator within 5 minutes after sudden power failure.

3) The food should be stored with spare space so as to facilitate the smooth circulation of cold air.

4) The temperature of the food to be stored in the refrigerator should not exceed the ambient temperature

- 5) Acids, alkaline, corrosive substance, volatile or inflammable materials cannot be stored in case of damage to the cabinet.
- 6) Cleaning: (Pull the plug out before cleaning the refrigerator). Mop the interior walls with a soft cloth dipped with neutral detergent; Exhaust the condensed water or mop it off with a dry clean cloth; the outsides can be cleaned with thin soda water or alcohol, and then mop clean with a cloth dipped with water.

6. GENERAL FAULTS AND TROUBLE-SHOOTING

In case of abnormal operation, please refer to the following diagrams for inspection and possible solutions. If the faults cannot be spotted, please contact the service department of our company or our local institutions with special engagement.

If the supply cord is damaged, it must be replaced by the manufacturer, its service agent or similarly qualified persons in order to avoid a hazard.

Faults	Causes	Solutions
Non-operation of the compressor	1. Loose contact	1. Make it tight
	2. Loose cables	2. Make it tight
Abnormal running of the compressor or unusual noise	Supply voltage 85% lower than the rated value	Switch the refrigerator off immediately until the recovery of the normal voltage supply. A voltage regulator with input power 5 times larger is required if the voltage fluctuation exceeds that specified.
The successive automatic shutoff of the compressor several minutes after startup again	The supply voltage 110% higher than the regulated power supply	
The storage temperature drops while the compressor is running properly	1. The cabinet is over loaded with tightly packed food	1. Arrange the food orderly with enough space between
	2. Too much frost accumulation	2. Take out the frozen food and remove the frost
	3. The exterior of the condenser is deposited with thick stains	3. Switch the machine off and unplug to clean the condenser
	4. Door leakage	4. Adjust the door sealing
Abnormal noise	1. The fridge is not positioned on a leveled floor	1. Adjust the machine to a more stable and leveled floor
	2. Loose fastening parts	2. Tighten the loose parts
	3. Unwanted contact between pipes	3. Keep the parts away from each other

The following should not be covered in the faults:

- 1) The surface temperature of the compressor may rise to a range between 70°C and 80°C.
- 2) The condensed water beads on the machine or door during the rainy seasons won't affect the operation of machine. The water beads may be wiped off with a dry cloth.

7. MAJOR TECHNICAL PARAMETERS

Model	NA-24-R
Power (V/Hz)	115/60
Capacity (L)	296
Temperature (°C)	0 to 10
Input power (kw/h/24h)	400
Power consumption	4.8
Refrigerant R-134a (g)	280
Net weight (kg)	95
Exterior dimensions (mm)	600 x 632 x 1874

8. NA-24R INTERIOR LAMP

- a) Unplug the power cord before service.
- b) Open the glass door.
- c) Remove lampshade by taking out screws on the right side.
- d) Separate the lamp from the lamp holder.
- e) Separate the lamp socket and replace the lamp with care.
- f) After replacement, ensure the lampshades are replaced.

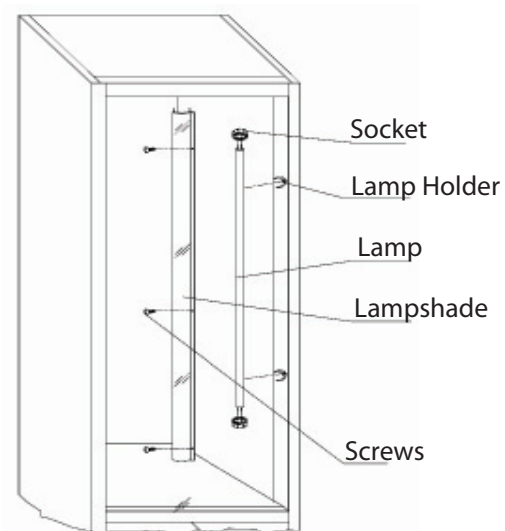

Figure 7

9. DISPOSAL OF OLD APPLIANCES

Be sure to make any locks unusable. If possible, remove any door(s) and discard separately.

WARNING-CHEMICAL HAZARD: Do not allow children to play with the old appliance. Contact your local authority for proper disposal procedures. Before disposing of an old appliance, please make sure it is switched off and safe. Unplug the appliance and break any locks in order to avoid children becoming trapped.

Please note: the refrigeration system contains gases and refrigerants which require specialist waste disposal. The valuable materials contained in a refrigerator can be recycled. Contact your local waste disposal depot for proper disposal of an old appliance and contact your local authority or dealer if you have any questions.

Please ensure the pipework of your refrigerator is not damaged prior to disposal. You can contribute to environmental awareness by insisting on an appropriate non-polluting method of disposal.

10. CIRCUIT DIAGRAM

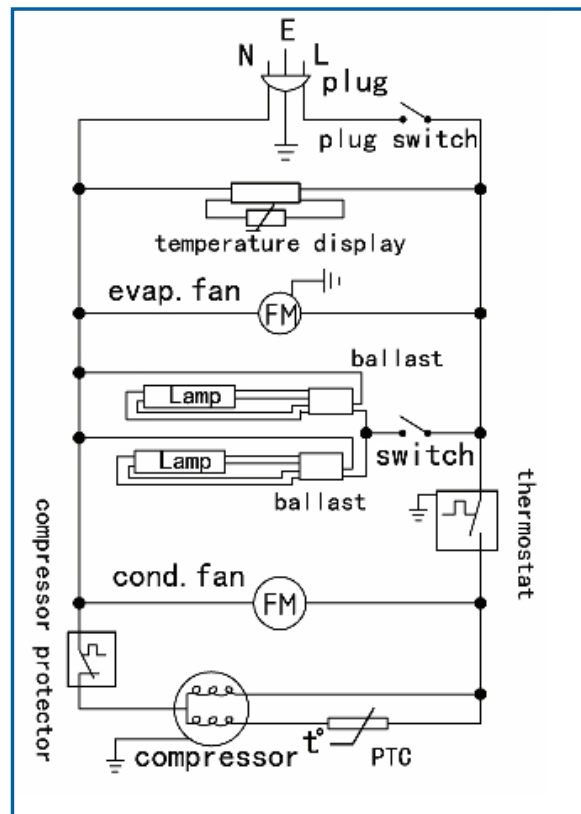

11. PACKING LIST

Product Type	NA-24-R
Refrigerator (Set)	1
User's Manual (Piece)	1
Material Shelf (Each)	5
K-Shaped Clamp (Each)	20

ONE YEAR PARTS & LABOR WARRANTY

NEW AIR warrants to the original purchaser of every NEW AIR refrigerated unit, the cabinet and all parts thereof, to be free from defects in material or workmanship, under normal and proper use and maintenance service as specified by NEW AIR and upon proper installation and start-up in accordance with the instruction packet supplied with each NEW AIR unit. NEW AIR obligation under this warranty is limited to a period of 1 year from the date of original installation or 15 months after shipment date from NEW AIR, whichever occurs first.

Any parts covered under this warranty that are determined by NEW AIR to have been defective within 1 year of original installation or 15 months after shipment date from manufacturer, whichever occurs first, is limited to the repair or replacement, including labor charges, of defective parts or assemblies. The labor warranty shall include standard straight time labor charges only, as determined by NEW AIR.

ADDITIONAL FOUR YEARS COMPRESSOR WARRANTY

In addition to the [one \(1\) year warranty](#) stated above, NEW AIR warrants its hermetically and semi-hermetically sealed compressors to be free from defects in both material and workmanship under normal and proper usage and maintenance service for a period of four (4) additional years from the date of original installation but not to exceed five (5) years and three (3) months after shipment from the manufacturer.

Compressors determined by NEW AIR to have been defective within this extended time period will, at NEW AIR's option, be either repaired or replaced with a compressor or compressor parts of similar design and capacity.

The four (4) year extended compressor warranty applies only to hermetically and semi-hermetically sealed parts of the compressor and **does not apply** to any other parts or components, including, but not limited to, cabinet, paint finish, temperature control, refrigerant, metering device, driers, motor starting equipment, fan assembly or any other electrical component, etcetera.

WARRANTY CLAIMS

All claims for labor or parts must be made directly through NEW AIR and [must have an authorization number](#). All claims should include: model number of the unit, the serial number of the cabinet, proof of purchase, date of installation, and all pertinent information supporting the existence of the alleged defect. In case of warranty compressor, the compressor tag must be returned to NEW AIR along with above listed information.

WHAT IS NOT COVERED BY THIS WARRANTY

NEW AIR sole obligation under this warranty is limited to either repair or replacements of parts, subject to the additional limitation below. This warranty neither assumes nor authorizes any person to assume obligations other than those expressly covered by this warranty.

NO CONSEQUENTIAL DAMAGES. NEW AIR is not responsible for economic loss; profit loss; or special, indirect, or consequential damages, including without limitation, losses or damages arising from food or product spoilage claims whether or not account of refrigeration failure.

Warranty is not transferable. This warranty is not assignable and applies only in favor of the original purchaser/user to whom delivered. Any such assignment or transfer shall void the warranties herein made and shall void all warranties, express or implied, including any warranty of merchantability or fitness for a particular purpose.

Not covered: travel time, overtime, weekend labor rate, time for cleaning, mileage, time for adjustments, time for normal maintenance, time to have access to the unit.

Improper usage: NEW AIR assumes no liability for parts or labor coverage for component failure or other damages resulting from improper usage or installation or failure to clean and/or maintain product as set forth in the warranty packet provided with the unit.

Residential applications: NEW AIR assumes no liability for parts or labor coverage for component failure or other damages resulting from installation in non-commercial or residential applications.

Alteration, neglect, abuse, misuse, accident, damage during transit or installation, fire, flood, acts of god: NEW AIR is not responsible for the repair or replacement of any parts that NEW AIR determines have been subjected after the date of manufacture to alteration, neglect, abuse, misuse, accident, damage during transit or installation, fire, flood, or act of god.

Improper electrical connections: NEW AIR is not responsible for the repair or replacement of failed or damaged components resulting from electrical power failure, the use of extension cords, low voltage, or voltage drops to the unit.

No implied warranty of merchantability or fitness for a particular purpose: There are any other warranties, expressed, implied or statutory, except the 1 year parts & labor warranty. There are no warranties which extend beyond the description on the face hereof.